

# MAIN DECK TOP VIEW

DECK PLATE TH: 8,0mm, STIFFENERS L100X50X8

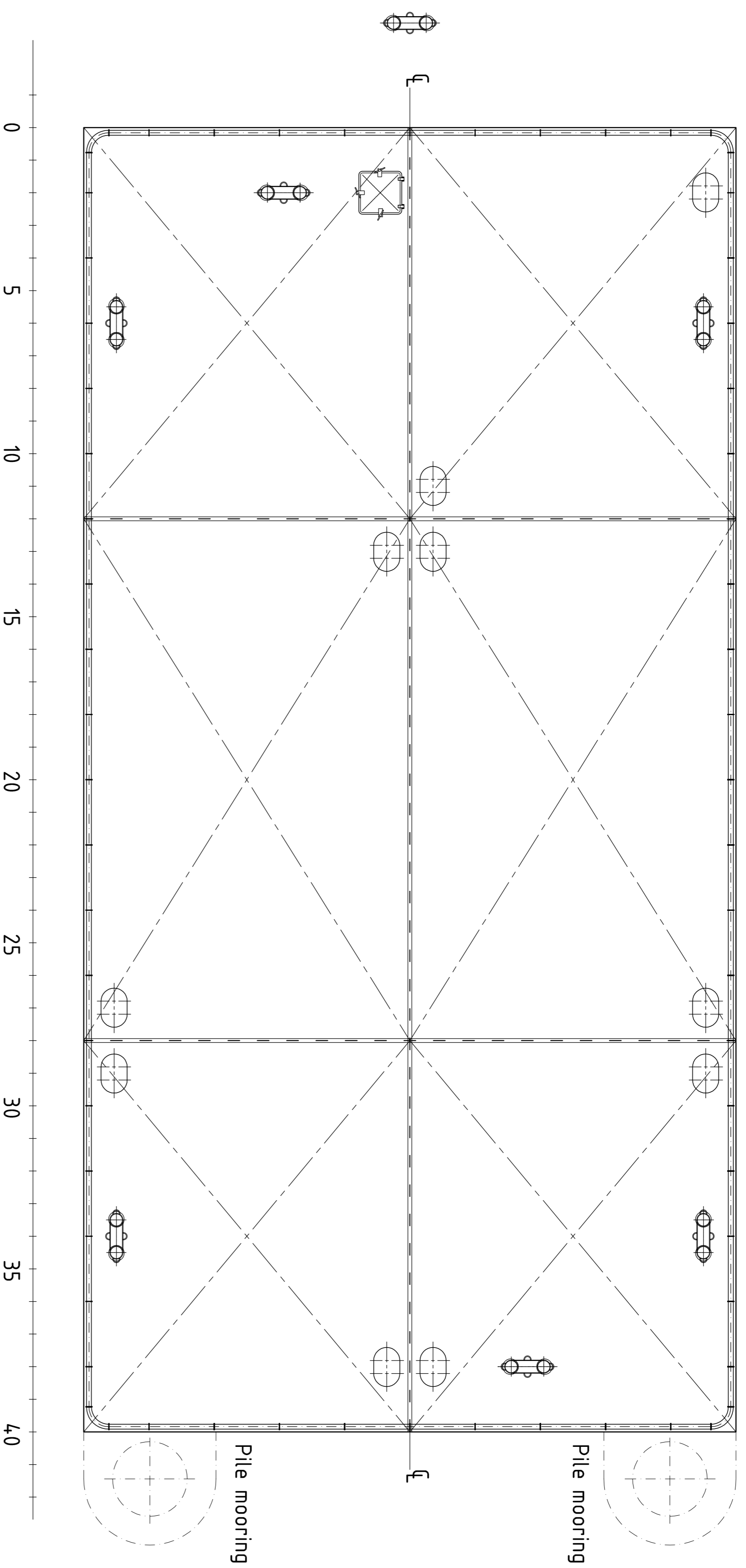

# TRANSOM

AFT VIEW

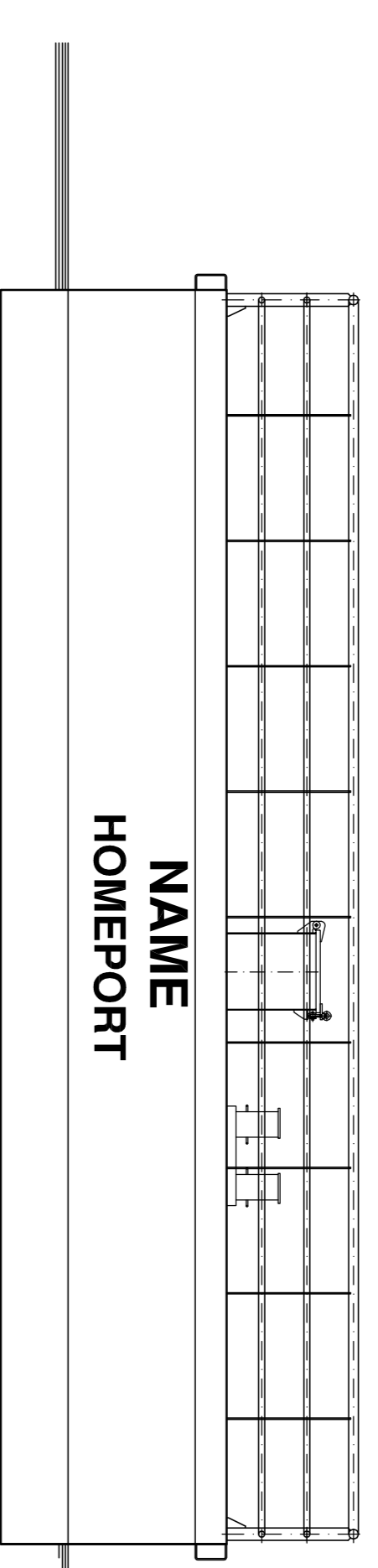

# SIDE VIEW

SIDE VIEW

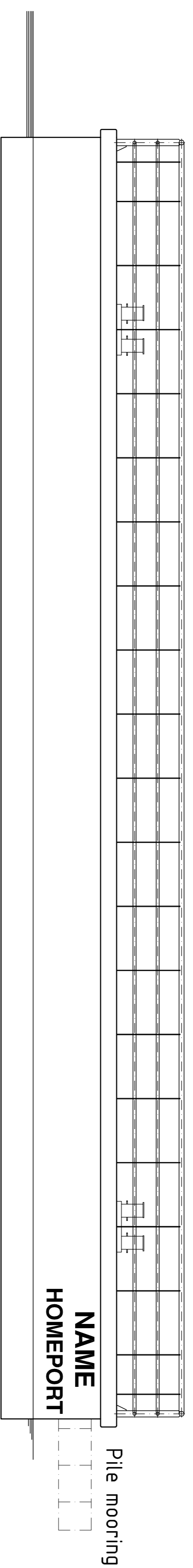

# DECK RAIL

1:10

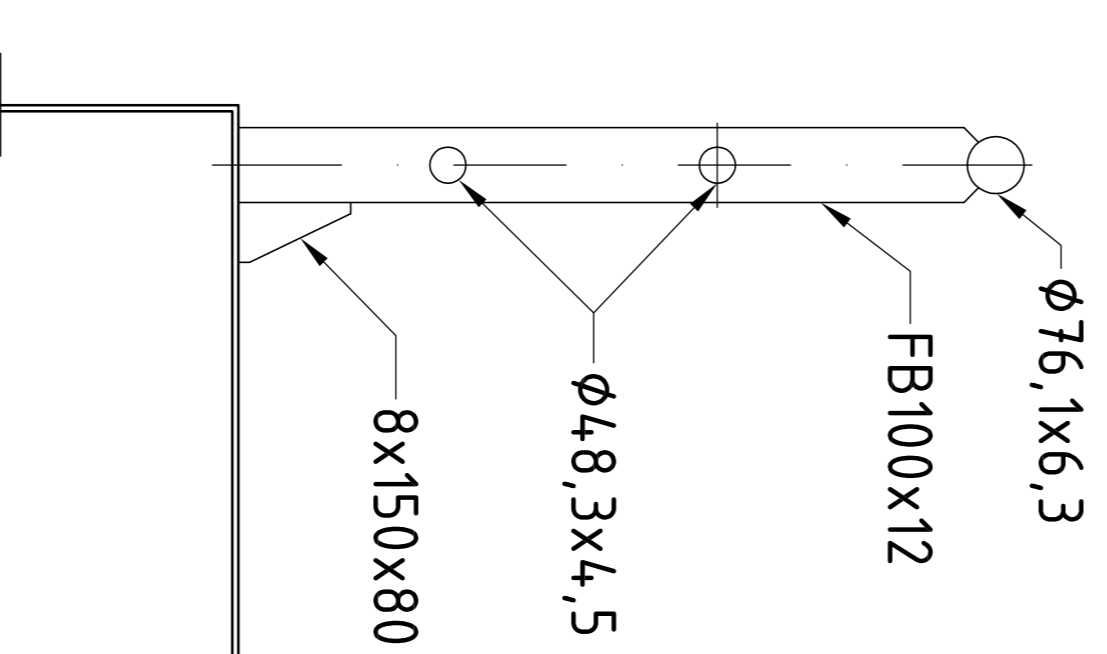

**NOTES:**

1. PILE MOORING DEVICE ACC. SEPARATE DRAWING

**MAIN DIMENSIONS:**

- Length - 20m
- Moulded Breadth - 10m
- FREE BOARD - 1,5m
- Depth - 1,8m
- Frame spacing - 0,5m
- Max deck load - 4,0 kN/qm
- Capacity - xxxx tons

Class society: DNV

The pontoon material: steel grade A with Dnv's certificates

Painting system: Hempel/Johnsen/International

Equipment: extra

Design by	28.09.2009	W.Fiedorowicz								
Checked by	--	--								
Approved by	--	--								
Issued by	--	--								
"STEEL BARGES"										
<b>STEEL BARGE 20X10X1,8m</b>										
GENERAL ARRANGEMENT										
MASS [kg]	SCALE	FORMAT	SURFACE	COPY No	INSTEAD OF DWG					Sheet Number
53000	1:50	A1			MODIFIC No					1
					ZT					1
					FILE NAME					
					PTS-SB-000-1					

# MAIN DECK

DECK PLATE 8mm, STIFF. L100x50x8  
BOTTOM PLATE SIMILAR

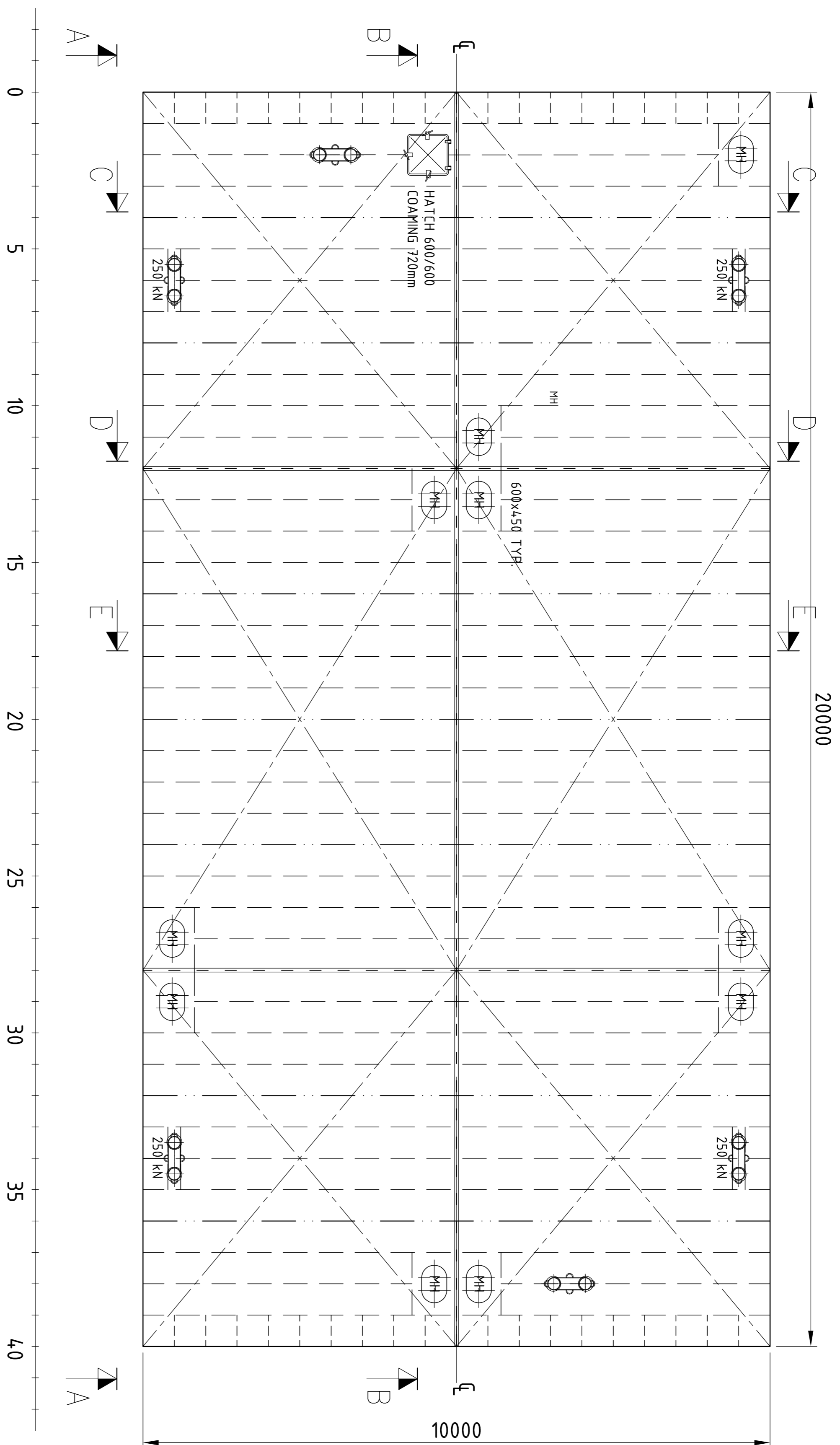

**A-A**  
PLATE 8mm, STIFF. L100x50x8  
STEEL FENDER C250x125x10

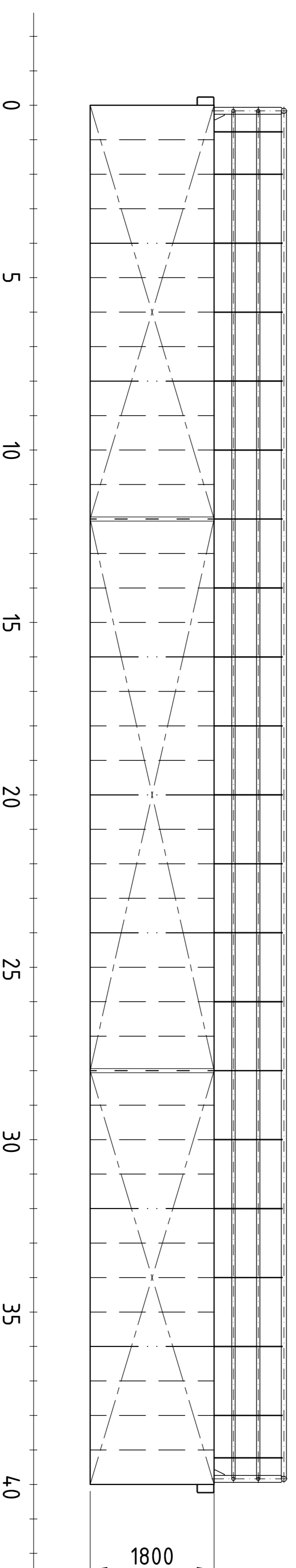

**B-B**  
BULKHEAD IN C.L.  
PLATE 8mm, STIFF. L100x50x8

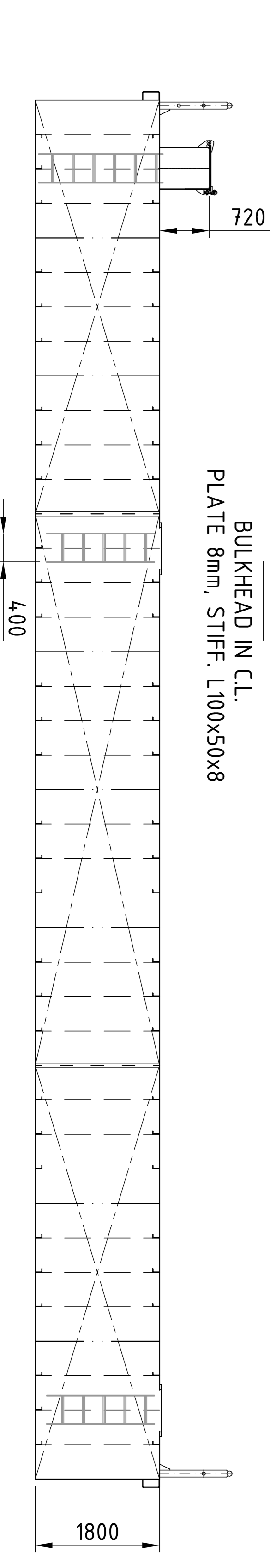

# D-D (TRANS. BHD.)

PLATE 8,0mm L100x50x8  
TRANSVERSAL BHD

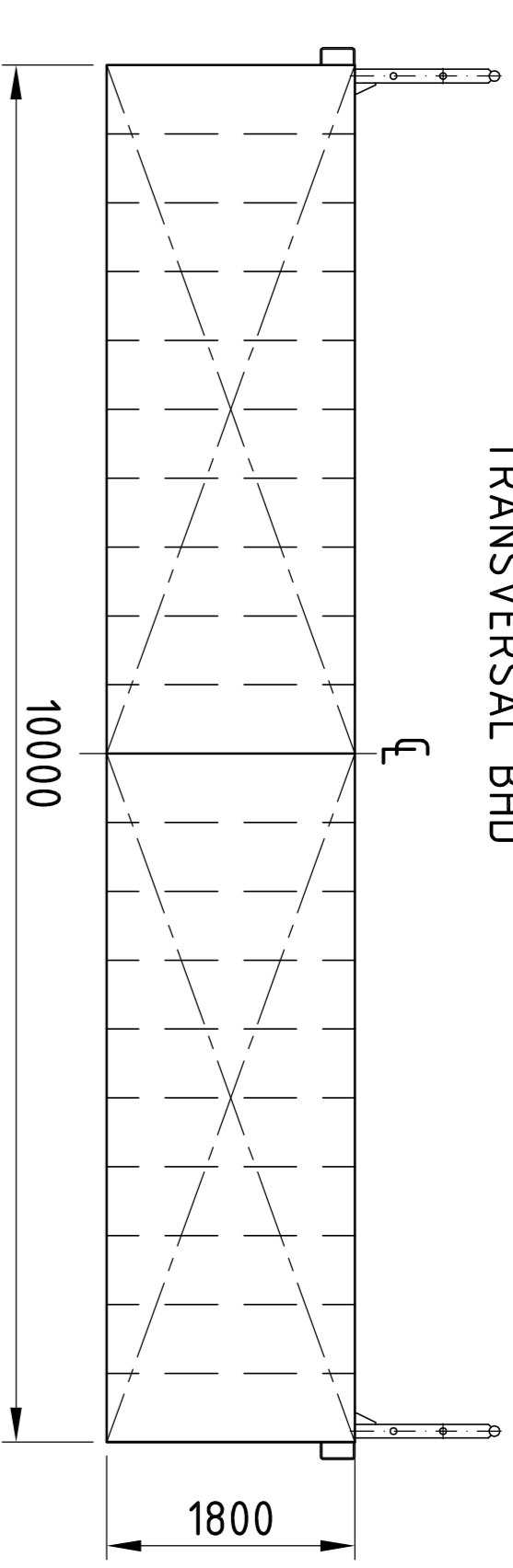

# C-C (WEB FRAME)

PLATE 8mm, VERT STIFF. L100x50x8  
OPENINGS FRAMING FB100x8

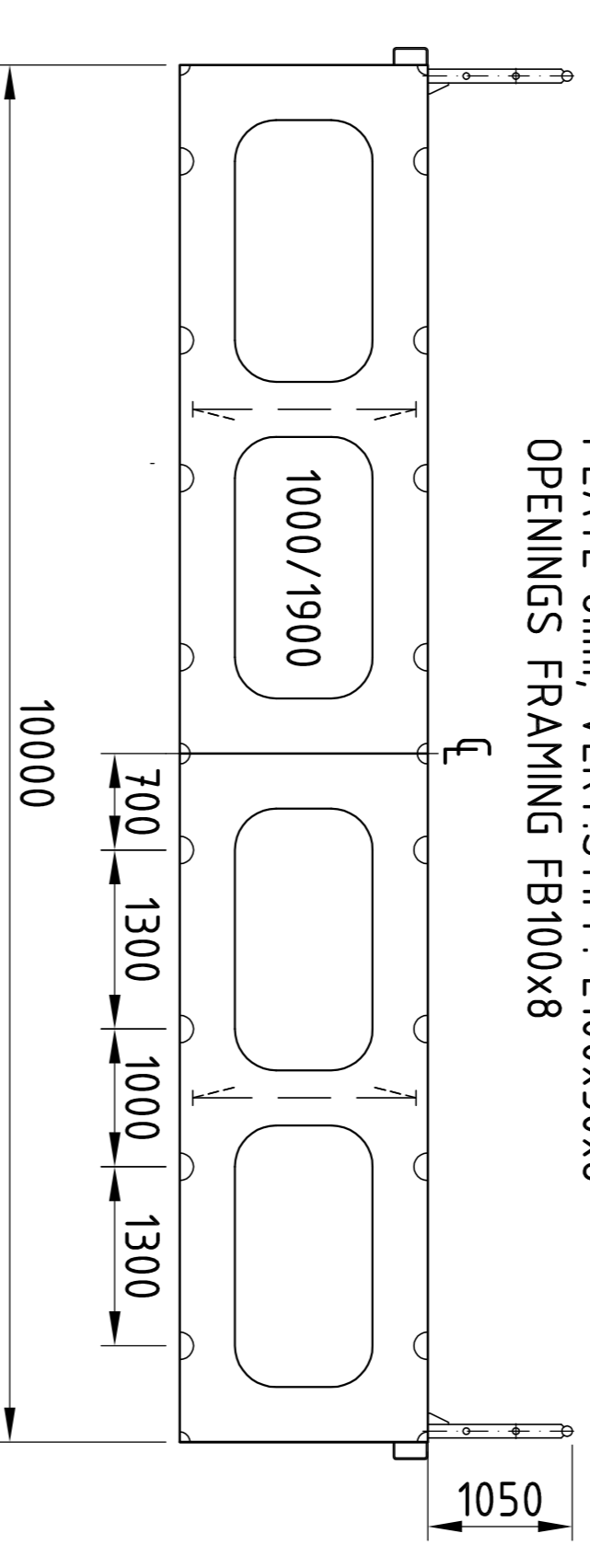

# E-E (NORMAL FRAME)

L100x50x8 BKT. 8x250x250

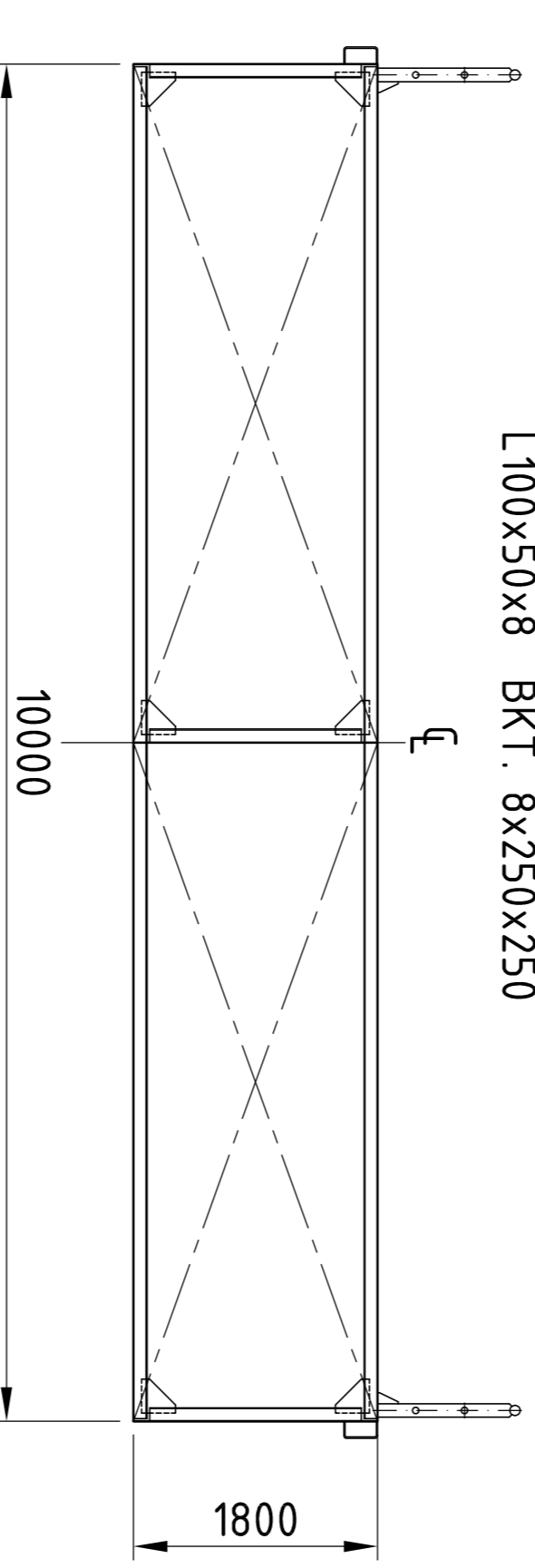

## NOTES:

1. FRAME SPACING - 500mm
2. GRADE MATERIAL - STEEL NVA
3. WELDING ACCORDING WELDING TABLE
4. REFERENCE DRAWINGS:  
MOORING PLAN,  
MANHOLE & BOTTOM PLUG PLAN,  
FENDER PLAN

Design by: 28.09.2009 M.Fiedorowicz

Checked by: -- --

Approved by: -- --

Issued by: -- --

Design by: 28.09.2009 M.Fiedorowicz

Checked by: -- --

Approved by: -- --

Issued by: -- --

Design by: 28.09.2009 M.Fiedorowicz

Checked by: -- --

Approved by: -- --

Issued by: -- --

TRAASS (kg)	SCALE	FORMAT	SURFACE	COPY No	FILE NAME	Sheet Number
53000	1:50	A1			PTS-SB-000-2	1 / 1

STEEL BARGE  
STEEL BARGE 20x10x1,8m

PROFILE AND DECKS

PROFIL AND DECKS

PROFIL AND DECKS

PROFIL AND DECKS

PROFIL AND DECKS

INSTEAD OF DWG	MODIFIC No	ZT	FILE NAME

PTS Ltd.

PTS Ltd.